

Overview

The **ECB-203** is a microprocessor-based programmable controller designed to control terminal units such as RTUs, FCUs, UVs, HPUs, AHUs, and chilled ceilings. This controller uses the BACnet® MS/TP LAN communication protocol and is BTL®-Listed as BACnet Application Specific Controllers (B-ASC).

The ECB-203 supports various input types including resistance, voltage, and digital-based ones. Moreover, it provides digital, floating, pulse width modulation, and proportional control outputs for valves, heating elements, fans, and lighting applications.

This controller works with a wide range of sensors, such as those in the EC-Smart-Vue series of communicating room sensors that feature a backlit display and graphical menus. These sensors are used for indoor temperature measurement, setpoint adjustment, fan speed selection, and occupancy state override. During commissioning, an EC-Smart-Vue can be used to perform system air balancing without requiring an onsite controls engineer and to troubleshoot the system. In addition, this controller is Open-to-Wireless® ready, and when paired with the Wireless Receiver, it works with a variety of wireless battery-less sensors and switches.

Custom program this controller using EC-gfxProgram through EC-Net^{AX} Pro which is powered by the Niagara^{AX} Framework®. This allows you to quickly and easily create your own control sequences capable of meeting the most demanding requirements of any engineering specification.

Applications

- Meets the requirements of the following applications:
 - Rooftop Units
 - Fan Coil Units
 - Chilled Ceilings
 - Heat Pumps
 - Unit Ventilators
 - Small Air Handling Units
- Improves energy efficiency when combined with:
 - Motion detectors to automatically adjust a zone's occupancy mode from standby to occupied when presence is detected
 - CO₂ sensors as part of a demand-controlled ventilation strategy that adjusts the amount of fresh air intake according to the number of building occupants
 - Light switches to control both lighting and a room's HVAC occupancy / standby mode setting
- Works with a wide range of wireless battery-less sensors

Features & Benefits

- Use the EC-gfxProgram's state-of-the-art visual programming wizard to create operation sequences that meet specific engineering specifications. EC-gfxProgram is accessible through EC-Net^{AX} Pro which is powered by the Niagara^{AX}-based management platform.
- Accelerate custom programming development by using pre-built HVAC control sequences supplied with EC-gfxProgram.
- Available with an optional Wireless Receiver that supports up to 24 wireless inputs, letting you create wire-free installations and use various wireless battery-less sensors and switches.
- With 6 software configurable universal inputs and 8 software configurable outputs, this controller covers all industry-standard HVAC unitary applications.
- Highly accurate universal inputs support thermistors and resistance temperature detectors (RTDs) that range from 0 Ohms to 350 000 Ohms, giving you the freedom of using your preferred or engineer-specified sensors, in addition to any existing ones.
- Rugged hardware Inputs and Outputs eliminate need for external protection components, such as diodes for 12V DC relays.

ECB-203 Controller



Model	ECB-203
Points	14-Point Controller
Universal hardware inputs	6
EC-Smart-View	4
Wireless inputs ¹	24
15 Vdc Power Supply	■
Digital (triac) outputs	5
Universal output	3
Product Number	CDIB-203X-00

1 All controllers are Open-to-Wireless ready. Available when an optional Wireless Receiver is connected to the controller. Some wireless sensors may use more than one wireless input from the controller.

Recommended Applications

Model	ECB-203
Rooftop Unit	■
2 Pipe Fan Coil	■
2 Pipe Fan Coil with Changeover Sensor	■
4 Pipe Fan Coil	■
Heat Pump Unit	■
Unit Ventilator	■
Small Air Handling Unit	■
Chilled Ceiling	■

BACnet Objects List

BACnet Calendar Objects	1
BACnet Schedule Objects	2
BACnet PID Loop Objects	8
BACnet BV Objects	
- Commandable	10
- Non-Commandable	40
BACnet MSV Objects	
- Commandable	10
- Non-Commandable	40
BACnet AV Objects	
- Commandable	25
- Non-Commandable	75

Open-to-Wireless – Wireless Receiver Add-on



Open-to-Wireless®

To reduce the cost of installation, and minimize the impact on existing partition walls, the Wireless Receiver enables this controller to communicate with a line of wireless battery-less room sensors and switches.



Wireless Receiver (315)	- Receiver for EnOcean® 315MHz wireless-enabled sensors and switches
Wireless Receiver (868)	- Receiver for EnOcean® 868.3MHz wireless-enabled sensors and switches

Note that controllers have one wireless port to support a single Wireless Receiver.

For more information about the EnOcean technology and Open-to-Wireless, refer to the Open-to-Wireless Solution Guide. For more information about the Wireless Receiver module, refer to the [Wireless Receiver Datasheet](#). These documents can be found on our web site at www.distech-controls.com.

Supported Platforms



EC-Net^{AX}

EC-Net^{AX} is a web-enabled multi-protocol integration solution powered by the Niagara^{AX} Framework, establishing a fully Internet-enabled, distributed architecture for real-time access, automation and control of devices. EC-Net^{AX}'s open framework creates a common development and management environment for integration of LONWORKS®, BACnet® and other protocols. Regardless of manufacturer and protocol, the EC-Net^{AX} system provides a unified modeling of diverse systems and data, providing one common platform for development, management and enterprise applications.

EC-Net^{AX} Wizards

EC-gfxProgram Graphical Programming Tool

Distech Controls' EC-gfxProgram is a programming tool that allows you to quickly create control sequences by "dragging and dropping" block objects and then linking the objects with a simple "click, select and release". Select objects from an extensive library of over 100 commonly used functions as well as create your own custom blocks. With a user-friendly interface and intuitive programming environment, HVAC programming could not be easier. Refer to the EC-gfxProgram datasheet for more information.

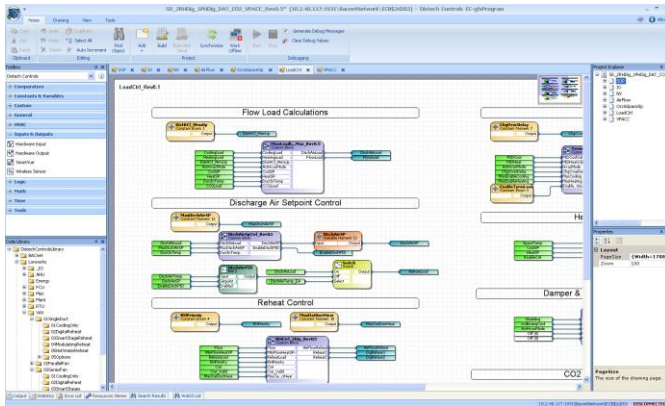

Scheduling Tool

Schedules and holidays are configured through the EC-NET^{AX} schedule configuration. It features a weekly schedule for regular, repeating, events by "time-of-day" and "day-of-week", while a holiday schedule is available to define events for specific days.

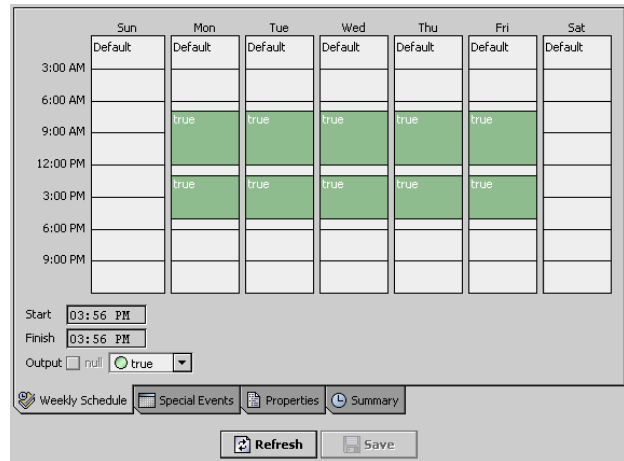

EC-gfxProgram Software Features:

- Program both ECP Series LonWorks and ECB Series BACnet controllers with the same tool
- Supplied as freeware – there are no associated licensing costs
- Block-oriented programming
- Live debugging allows user to view code execution, input/output values and to detect errors in real-time
- Furnished with *gfxApplications*: A library of standard pre-coded and tested HVAC sequences that suit most field applications while allowing you to make your own modifications if necessary. For example, this library supports the following applications:
 - VAV
 - Air Handling Unit
 - Fan Coil Unit, and more
- Extensive block library of the most commonly used functions divided into 11 convenient categories containing over 100 block objects
- A code library for managing your favorite or most commonly used code or code sections
- Backup / Restore function stores the complete code in the controller allowing the retrieval of all programming code features
- The following advanced features are available with the ECB Series and controllers:
 - Advanced mathematical functions such as sin, cosine, power, exponential, logarithm, and so on
 - For loop can be used to find highest, lowest, and average values

Scheduling Wizard Features

- Easily configure schedules using a graphical slider
- Allows you to easily copy and paste entries
- Duplicate a schedule entry for Monday to Friday
- Special events allow you to set exceptions such as holidays to a schedule
- Holidays can be set for recurring events such as the 9th day, or the 3rd Thursday of a given month
- A schedule has an effective period during which it is active
- Schedule provides Next State and Time to Next State that are ideal for use with programming functions such as Optimum Start or morning Warm Up.

Complementary Products

Temperature Sensors

Allure EC-Smart-Vue

Line of communicating sensors with backlight display and graphical menus. Terminal unit commissioning can start immediately after installation, as it can be used as a hand-held tool. This sensor is used to set the ECB-203's network address, to select the appropriate terminal unit controller application in use, and to troubleshoot the system.



EC-Smart-Vue	Communicating room temperature sensor with backlight display and graphic menus
EC-Smart-Vue-H	Communicating room temperature and humidity sensor with backlight display and graphic menus

Allure EC-Sensor

Line of discrete sensors



EC-Sensor	Room temperature sensor with communication jack
EC-Sensor-O	Room temperature sensor with occupancy override button and communication jack
EC-Sensor-S	Room temperature sensor with setpoint adjustment and communication jack
EC-Sensor-SO	Room temperature sensor with setpoint adjustment, occupancy override button, and communication jack
EC-Sensor-SOF	Room temperature sensor with setpoint adjustment, occupancy override button, fan speed selection, and communication jack

Open-to-Wireless Sensors and Switches (requires Wireless Receiver)

Allure Wireless Battery-less ECW-Sensor

Line of wireless, battery-less sensors. Available in EnOcean 315MHz and 868.3MHz versions.



ECW-Sensor	Room temperature sensor
ECW-Sensor-O	Room temperature sensor with occupancy override button
ECW-Sensor-S	Room temperature sensor with setpoint adjustment
ECW-Sensor-SO	Room temperature sensor with setpoint adjustment and occupancy override button
ECW-Sensor-SOF	Room temperature sensor with setpoint adjustment, occupancy override button, and fan speed selection

Wireless Sensors and Switches



SR-MDS	Wireless solar-cell powered motion detector and light sensor for room occupancy detection and/or lighting applications. Available in EnOcean 315MHz and 868.3MHz versions.
--------	--



2-channel Light Switch	2-/4-channel wireless light switches (European models). Available in EnOcean 315MHz and 868.3MHz versions.
4-channel Light Switch	



PTM265	2-/4-channel wireless light switches (North American models). Available in EnOcean 315MHz and 868.3MHz versions.
PTM265D	



E3T-C2AWH (315 MHz)	Key card holder, white, wireless. Available in EnOcean 315MHz and 868.3MHz versions.
E8T-C2AWH (868 MHz)	



SR65	Wireless, solar-cell powered outdoor temperature sensor. Available in EnOcean 315MHz and 868.3MHz versions.
------	---



SR65 AKF Series	Wireless, solar-cell powered duct temperature sensor. Available in EnOcean 315MHz and 868.3MHz versions.
-----------------	--

For more information about the available wireless sensors and switches, refer to the [Open-to-Wireless Solution Guide](#) which can be found on our web site at www.distech-controls.com.

For more information on these or other Distech Controls products please refer to our web site at www.distech-controls.com or contact sales@distech-controls.com.

Controller Dimensions

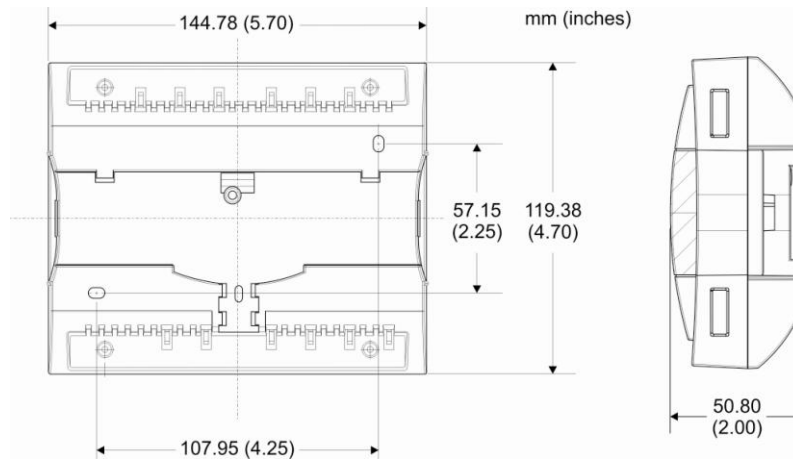

Product Specifications

Power

Voltage	24VAC/DC; $\pm 15\%$; 50/60Hz; Class 2
Protection	2.0A user-replaceable fuse
Power Consumption	14 VA typical plus all external loads 23 VA maximum

Interoperability

Communication Bus	BACnet MS/TP
BACnet Profile	B-ASC ¹
EOL Resistor	Built-in, jumper selectable
Baud Rates	9600, 19 200, 38 400, or 76 800 bps
Addressing	Dip Switch

Hardware

Processor	STM32 (ARM Cortex™ M3) MCU, 32 bit
CPU Speed	68 MHz
Memory	384 kB Non-volatile Flash (applications) 1 MB Non-volatile Flash (storage) 64 kB RAM
Status Indicator	Green LEDs: Power Status & LAN Tx Orange LEDs: Controller Status & LAN Rx
Communication Jack	BACnet 1/8" (3.5mm) stereo audio jack

Environmental

Operating Temperature	0°C to 50°C; 32°F to 122°F
Storage Temperature	-20°C to 50°C; -4°F to 122°F
Relative Humidity	0 to 90% Non-condensing

Enclosure

Material	ABS type PA-765A
Color	Blue casing & grey connectors
Dimensions (with Screws)	5.7" x 4.7" x 2.0" (144.8mm x 119.4mm x 50.8mm)
Shipping Weight	0.97lbs (0.44kg)
Installation	Direct din-rail mounting or wall mounting through mounting holes (see figure above for hole positions)

Inputs

Input Types	Universal; software configurable
-Voltage	- 0 to 10VDC (40k Ω input impedance) - 0 to 5VDC (high input impedance)
-Current	0 to 20mA with 249 Ω external resistor (wired in parallel)
-Digital	Dry contact
-Pulse	Dry contact; 500ms minimum ON/OFF
-Resistor	0 to 350 K Ω . All thermistor types that operate in this range are supported. The following temperature sensors are pre-configured:
<i>Thermistor</i>	10K Ω Type 2, 3 (10K Ω @ 25°C; 77°F)
<i>Platinum</i>	Pt1000 (1K Ω @ 0°C; 32°F)
<i>Nickel</i>	RTD Ni1000 (1K Ω @ 0°C; 32°F) RTD Ni1000 (1K Ω @ 21°C; 69.8°F)
Input Resolution	16-bit analog / digital converter
Power Supply Output	15VDC; maximum 120mA (6 inputs x 20mA each)

Outputs

Digital	24VAC Triac, digital (on/off), floating, or PWM; software configurable
	- 0.5A continuous
	- 1.0A @ 15% duty cycle for a 10-minute period
	- PWM control: adjustable period from 2 to 65sec.
	- Floating control:
	- Min pulse on/off: 500msec.
	- Adjustable drive time period
External power supply	0-10VDC linear, digital 0-12VDC (on/off), floating or PWM; software configurable. Built-in snubbing diode to protect against back EMF, for example when used with a 12VDC relay.
	- PWM control: adjustable period from 2 to 65sec.
	- Floating control:
	- Min pulse on/off: 500msec.
	- Adjustable drive time period
	- 60mA max. @ 12VDC (60°C; 140°F)
	- Minimum resistance 200 Ω
	- Auto-reset fuse
	- 60mA @ 60°C; 140°F
	- 100mA @ 20°C; 68°F
Output Resolution	10-bit digital / analog converter

Product Specifications (continued)

Wireless Receiver²

Communication	EnOcean wireless standard
Number of wireless inputs ³	24
Supported Wireless Receivers	Wireless Receiver (315) Wireless Receiver (868)
Cable	Telephone cord
- Connector	4P4C modular jack
- Length	6.5ft; 2m

Electromagnetic Compatibility

CE -Emission	EN61000-6-3: 2007; Generic standards for residential, commercial and light-industrial environments
-Immunity	EN61000-6-1: 2007; Generic standards for residential, commercial and light-industrial environments
FCC	This device complies with FCC rules part 15, subpart B, class B



EC-Smart-Vue

Communication	RS-485
Number of sensors per controller	Up to 4, in daisy-chain configuration
Cable	Cat 5e, 8 conductor twisted pair
Connector	RJ-45



Agency Approvals

UL Listed (CDN & US)	UL916 Energy management equipment
Material ⁴	UL94-5VA



Communication Protocols



1. Refer to Distech Controls' Protocol Implementation Conformity Statement for BACnet.
2. Available when an optional external Wireless Receiver module is connected to the controller. Refer to the Open-to-Wireless Solution Guide for a list of supported EnOcean wireless modules.
3. Some wireless modules may use more than one wireless input from the controller.
4. All materials and manufacturing processes comply with the RoHS directive  and are marked according to the Waste Electrical and Electronic Equipment (WEEE) directive .

Product Warranty & Total Quality Commitment

All Distech Controls product lines are built to meet rigorous quality standards and carry a two-year warranty. Distech Controls is an ISO 9001 registered company.

Specifications subject to change without notice.

Distech Controls, the Distech Controls logo, and Open-To-Wireless are trademarks of Distech Controls Inc.; LONWORKS is a registered trademark of Echelon Corporation; Niagara^{AX} Framework is a registered trademark of Tridium, Inc.; ARM Cortex is a registered trademark of ARM Limited; BACnet is a registered trademark of ASHRAE; BTL is a registered trademark of the BACnet Manufacturers Association; Windows, Visual Basic.Net are registered trademarks of Microsoft Corporation. EnOcean is a registered trademark of EnOcean GmbH. All other trademarks are property of their respective owners.



05DI-DSEB203-13

ECB-203

www.distech-controls.com